

# DAYBLAZER 1100™

USB Rechargeable Light  
Rechargeable Via Câble USB  
Aufladbare USB Leuchte  
Part# 7097039

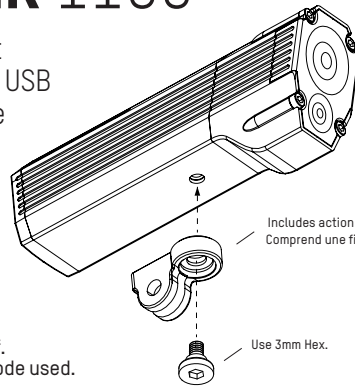

Includes action camera style mount  
Comprend une fixation pour caméra d'action

Use 3mm Hex.

1. Push button to power on.
  2. Click to cycle modes.
  3. Hold down 1 second to power off.
- Light powers back on in the last mode used.

The light indicator will blink when charging. When charging is complete the light indicator with flash green.

GREEN = 100% to 75% Battery Capacity  
ORANGE = 75% to 25% Battery Capacity  
RED = <25% Battery Capacity

When battery capacity is 25-35 minutes or less, red indicator light will remain on constant until light reaches 0% or turns off in the selected mode.

MAKE SURE TO FULLY CHARGE LIGHT BEFORE FIRST USE

1. Appuyez sur le bouton pour allumer.
  2. Cliquez pour faire défiler les modes.
  3. Maintenez le bouton enfoncé pendant 1 seconde pour éteindre.
- La lampe se rallumera dans le dernier mode utilisé.

L'indicateur lumineux clignote pendant la charge. Quand la charge est complète, l'indicateur lumineux clignote en vert.

ERT = Capacité des piles de 100 % à 75 %  
ORANGE = Capacité des piles de 75 % à 25 %  
ROUGE = Capacité des piles < 25 %

Quand l'éclairage ne peut durer que 25 à 35 minutes ou moins, l'indicateur lumineux rouge reste constamment allumé jusqu'à ce que la capacité atteigne 0 % ou que la lampe s'éteigne dans le mode choisi.

VÉRIFIER QUE L'ÉCLAIRAGE EST TOTALEMENT CHARGÉ AVANT LE PREMIER USAGE

1. Druckknopf EIN.
2. Klicken, um Modi auszuführen.
3. Halten Sie 1 Sekunde AUS.

Beim Laden blinkt die Anzeige. Grünes Licht zeigt an, dass der Ladevorgang abgeschlossen ist.

RÜN = 100% bis 75% Batteriekapazität  
ORANGE = 75% bis 25% Batteriekapazität  
ROT = <25% Batteriekapazität

Beträgt die Batteriekapazität 25-35 Minuten oder weniger, bleibt das rote Licht ständig an, bis die Leuchte 0% erreicht oder sich im gewählten Modus abschaltet.

SICHERSTELLEN, DASS DIE LEUCHE VOR DEM ERSTEN GEBRAUCH VOLLSTÄNDIG GELADEN IST

- \* Ask your retailer for full warranty policy or visit [www.blackburndesign.com/warranty](http://www.blackburndesign.com/warranty)
- \* Demandez à votre détaillant tous les détails de la politique de garantie ou consultez le site [www.blackburndesign.com/warranty](http://www.blackburndesign.com/warranty)
- \* Wenden Sie sich bezüglich der Vollgarantie bitte an Ihren Einzelhändler oder besuchen Sie [www.blackburndesign.com/warranty](http://www.blackburndesign.com/warranty)

Visit us at [blackburndesign.com](http://blackburndesign.com) for product updates

Visitez le site Internet [blackburndesign.com](http://blackburndesign.com) pour obtenir les mises à jour sur les produits  
Informationen über Produktverbesserungen finden Sie unter [www.blackburndesign.com](http://www.blackburndesign.com)

**Blackburn**

Customer Service: 1-800-456-2355  
[Blackburndesign.com](http://Blackburndesign.com)  
Printed in China

**▲ WARNINGS:** Potential choking hazard to children. This light is extremely bright—do not aim directly into eyes. UK ONLY: When used for cycling, this light should be used in conjunction with a British Standard 6102/3 cycle light.

**▲ AVERTISSEMENT :** Danger possible d'étouffement pour les enfants. Cette lampe est extrêmement brillante – ne pas diriger le faisceau directement dans les yeux.

**▲ WARNUNG:** Potenzielle Erstickungsgefahr für Kinder. Dieses Licht ist extrem hell. Nicht direkt in die Augen richten!

**LIMITED  
LIFETIME  
WARRANTY**  
\* RESTRICTIONS & CONDITIONS APPLY

Push to turn on / Cycle Modes / Hold down to turn off  
Appuyer pour allumer/cycler dans les différents Modes / Maintenir enfoncé pour éteindre

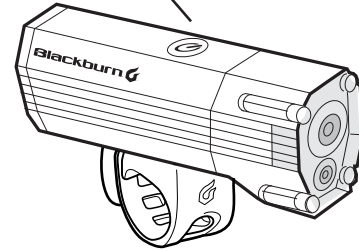

Micro-USB

Plug into Micro USB port / Plug into computer USB port  
Brancher sur le port USB / Brancher sur le port USB de l'ordinateur

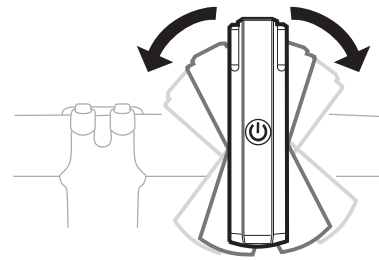
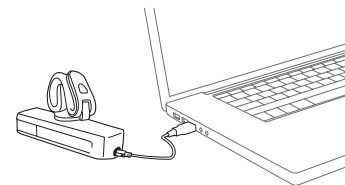
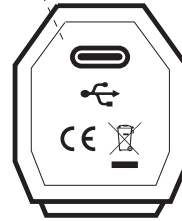

FL-T STANDARD	BLITZ	HIGH	LOW	PULSE	STROBE
	<b>1100</b> LUMENS	<b>800</b> LUMENS	<b>400</b> LUMENS	<b>200</b> LUMENS	<b>200</b> LUMENS
	<b>1</b> hrs	<b>2</b> hrs	<b>3</b> hrs	<b>7</b> hrs	<b>12</b> hrs
	<b>6700</b> cd	<b>4800</b> cd	<b>2400</b> cd	<b>1200</b> cd	<b>1200</b> cd
	<b>IP-67</b>				

This equipment has been tested and found to comply with the limits for a Class B digital device, pursuant to Part 15 of the FCC Rules. These limits are designed to provide reasonable protection against harmful interference in a residential installation. This equipment generates, uses and can radiate radio frequency energy and, if not installed and used in accordance with the instructions, may cause harmful interference to radio communications. However, there is no guarantee that interference will not occur in a particular installation. If this equipment does cause harmful interference to radio or television reception, which can be determined by turning the equipment off and on, the user is encouraged to try to correct the interference by one or more of the following measures: • Reorient or relocate the receiving antenna. • Increase the separation between the equipment and receiver. • Connect the equipment into an outlet on a circuit different from that to which the receiver is connected. • Consult the dealer or an experienced radio/TV technician for help. Shielded interface cable must be used with the equipment in order to comply with the limits for a digital device pursuant to Subpart B of Part 15 of FCC Rules. Specifications and designs are subject to change without any notice or obligation on the part of the manufacturer.